

Safe Electric Mobility for Women Rider

HiwaniSingh³, KshitijShinghal¹, Amit Saxena², Shahbaz Khan³, Mini Katariya³

¹Head of the Department, Electronics and Communication Engineering department, Moradabad Institute of Technology, Moradabad

²Assistant Professor, Electronics and Communication Engineering department, Moradabad Institute of Technology, Moradabad

³Student, Bachelor of Technology (ECE), Moradabad Institute of Technology, Moradabad

Date of Submission: 14-06-2020

Date of Acceptance: 30-06-2020

ABSTRACT

The safety measure of women is a major concern due to rising number of crimes. Also, the various hazards caused to life due rise in amount of CO₂ is a rising concern, since many individuals prefer using vehicle. Also, due to rise in number of vehicle users, the chances of injury and accidents have increased. This scooty can be a solution to all problems mentioned above. This electric mobility has performance and safety features such as, shock mechanism, spray system, GPS and GPRS, accident alert, collision alert, and side-stand shut off, helmet reminder, dual fuel and solar charging, which are introduced for the safety of the rider. In this paper, a hybrid electric vehicle specially designed for the safety of women is discussed.

KEYWORDS – safe electric mobility, shock mechanism, accident alert, solar charging, women safety, hybrid bike.

I. INTRODUCTION

There are many issues faced in the country, currently. One of the major concerns is related to the safety of women, since violence against humanity has increased. Another major concern is the constant change in the weather due to pollution created by the men. One main cause of air pollution is the smoke that comes from the vehicles. Lastly, there is an increase in the number of accidents, as the world is in fast pace and most people are mostly in rush. Noticing all these issues, the motivation leads to reduce as many issues of the country, as possible, as discussed in this paper. Therefore, a model is designed of an electric mobility, concentrating more on the safety of the women. Since India has a target to have an all-electric car fleet with an objective of lowering the fuel import and running cost of vehicles by 2030, most people could start using electric vehicles. In this paper, a proposed model is discussed about the hybrid vehicle that is specially

designed for the safety of women. The paper is organized in different sections.

The proposed model is introduced in section 1, wherein the authors have introduced the model of this vehicle along with various issues due to which the authors have designed the following model. In section 2 the background of the electric vehicle is explained, giving knowledge about various issues in India which had to be solved. Section 3 gives the description of the block diagram of the electric vehicle designed by the authors. Section 4 explains about the features of the project in detail; which is divided into safety and performance features. The features included in each of these are explained in detail. The result obtained after designing and practical implementation is presented in section 5. The advantages of using this model is explained in section 6 by focusing about the positive impacts of this vehicle, the paper is concluded in section 7 and finally future scope of the work is presented in the last section of the paper.

II. BACKGROUND

By the end of the nineteenth century, the internal combustion engines developed the automobiles which were one of the greatest achievements in engineering. There was an availability of low-cost fuels, ease of use, increased reliability and long driving range which boosted the acceptance of these vehicles [1]. The number of vehicle use has increased with a tremendous amount up to date. According to statistics, 67.4 lacs units are sold per year and two-wheeler riders have increases from 5-10% every year.

In India, almost every person rides a two-wheeler, but the increase in number of crimes has lead to question of safety. There is a rise in the number of crimes against humanity with an alarming rate. Therefore, the concern regarding the safety of women on road is one of the major concerns. Nearly four out of five road users are threatened with physical violence every day. Many drivers, cyclists, pedestrians, runners use the road, and it was found

that 18% had faced threats. Therefore, the model is designed with various features to help the rider with the safety.

The second major concern on the country is the poisonous CO₂ gas that is emitted from the vehicles. However, vehicles that move by heat engines having fuel efficient very poor (~ 20-25%); moreover, the hydrocarbon fuels in these vehicles when combust, they release many toxic gases. The automotive industry and the increase in number of vehicles users with a large amount have caused a serious concern to the environment and human.

The transport sector is a major contributor of air pollution besides electricity and heat generation industries. The rate of Carbon Monoxide (CO) and Carbon Dioxide (CO₂) suddenly increased at the dangerous level which made a negative impact on Ecosystem. As shown in Fig. 1, the electricity and heat generation sectors contribute to 42% of the global CO₂ emissions, while the transport sector alone contributes to 24% of CO₂ emissions.[1][2]

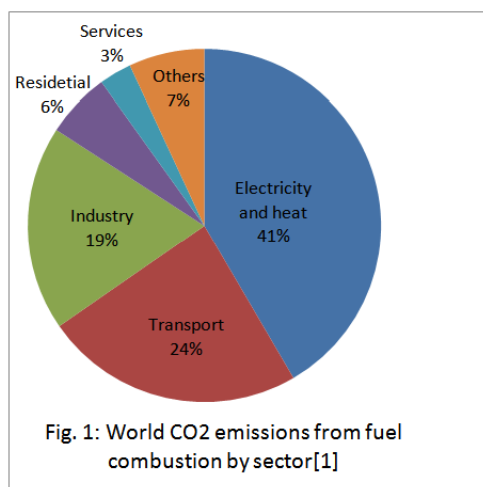

Fig. 1: World CO₂ emissions from fuel combustion by sector[1]

Automobile sector is facing major challenges today; as follows (I) how to reduce impacts on climate change and (II) how to lower dependence on oil fuel. Keeping these points in mind, this vehicle is designed accordingly, to solve the above challenges. [3]

India has a target that, by 2030, there should be an all electric-car fleet. And their objective is to lower the import of fuel and the running cost of vehicle. As a starting point in this direction, Govt. of India launched the National Electric Mobility Mission Plan (NEMMP)-2020 in 2013. It aims to achieve national fuel security by promoting hybrid and electric vehicles in the country. The ambitious target is to achieve sales of 6-7 million hybrid and

EVs per year starting from 2020, out of which 4-5 million are expected to be two-wheelers. [11]

Approximately 1.3 million people die each year on the world's roads, and between 20 and 50 million sustain non-fatal injuries, according to survey. The number of road traffic deaths continues to rise steadily, reaching 1.35 million in 2016. Head injuries are the leading cause of death and major trauma for two- and three-wheeled motor vehicle users. Correct helmet use can lead to a 42% reduction in the risk of fatal injuries and a 69% reduction in the risk of head injuries. The use of helmets, as such, an increasingly important means of preventing road traffic deaths. [13]

III. BLOCK DIAGRAM OF THE ELECTRIC VEHICLE

The basic block diagram of the system is shown Fig. 2. The microcontroller is controlling all the functions of the scooter, as shown. The various safety measures installed in the scooter are controlled by the microcontroller. The GSM and GPRS modules are used for the purpose of communication with the guardian or family, along with providing the location of the rider when the rider is in danger. The BLDC motor is used in the vehicle to ride the vehicle in electricity mode, which is furthermore discussed in the following section.

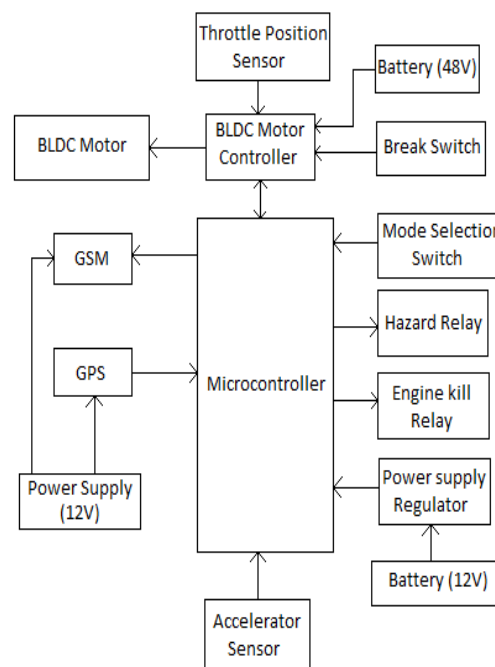

Fig. 2: Basic block diagram of the safe electric mobility

IV. FEATURES IN THE ELECTRIC VEHICLE

The proposed model designed is specially designed for the women rider. This scooty is equipped with special various features; which can be categorized into two groups:

- Safety
- Performance



Fig. 3: Real-time photo of the designed vehicle

➤ Safety Features

Initially, the safety features introduced in this vehicle will be discussed. As mentioned earlier, the proposed model is designed especially for the women rider; therefore, the safety features in this vehicle are explained as follows:

1. Shocking mechanism

The scooty has a detachable rod which has a high voltage and a very low current arc is produced with the help of step up power module high voltage generator. If an encounter takes place with some attacker while riding, then this rod can be detached and electric current can be given to the attacker.

2. Spray system

The handle of the scooty has a spray system filled with pepper spray. This spray can be sprayed on the attacker if he comes in front of the rider. By directing the handle to where the attacker is, the rider can spray the pepper spray by pressing a button, which is provided. When this button is pressed, the motor gets activated and it produces a pressure injection from the nozzle.

3. GPS and GPRS

The GPS and GPRS present in the scooty will provide location of the scooty, while the GSM is present to send message. This system will in sending the location and a message to parents/guardian or police and it can be used by the rider when she needs help.

4. Panic button

This button will come in help to the rider when attacker attacks the rider suddenly. When this button is pressed, a loud siren is activated along with the headlights and the indicator to glow. The siren and the indicator help in gaining attention from the surrounding. And, a message along with the location is sent to the parent/guardian and the police.

5. Accident alert

If the rider meets with an accident, then all the systems of the scooty turn off to avoid any fire calamity that could be caused due to short circuit, and the buzzer and indicator turn on, to gain attention to help the rider.

6. Collision alert

When the rider rides scooty and a vehicle comes behind too close, about 1 meter or less, to the scooty then the scooty makes a beep sound to alert the rider to maintain gap and avoid collision.

7. Helmet reminder

This scooty is paired with a special helmet which is equipped with a microcontroller, switch and a wireless network module. When the rider rides the scooty, then those devices sense whether the rider is wearing the helmet or not. If helmet is not worn, then the scooty makes a beep sound. This way the safety of the rider is ensured.

➤ Performance Features

Along with the safety features, the vehicle has some important performance measures, which are discussed further. The following measures are included in the performance feature:

1. Dual fuel

This scooty can work on petrol as well as electricity. For this purpose, a BLDC hub motor is used, controller and an electric throttle for control. BLDC hub motor (as show in fig 4) is supplied with a separate battery supply of 48 V and 20AH. These batteries are placed under the set which makes body weight to align at the centre and centre of body below mean high. This leads to maintaining a balance while riding. Li-ion battery is used in this scooty, due to its compact size, low weight and high power output. [15]



Fig. 4: Real time photo BLDC hub motor on front Wheel of scooty.

Motor is fixed on the front wheel and controlled with an esoteric BLDC motor controller unit. Hub motor is used because it does not require motor and wheel coupling; since hub is works as a motor as well as wheel itself.

2. Solar charging

Scooty has 3 terminals,(A),(B) and (C)for different solar panel configuration,the connections on different terminals can be made as shown in the figure,

- For 24V panel, the connection can be either (A) to (B), or (B) to (C).
- For 48V panel, the connections are made between (A) to (C).

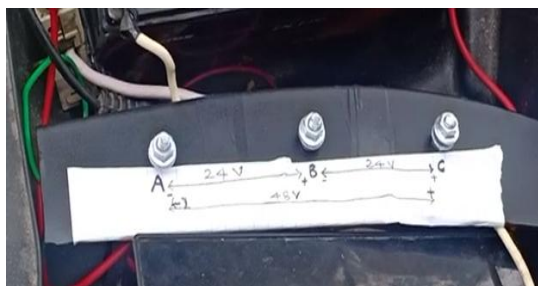

Fig. 5: Configuration for connection of solar panels

V. RESULT

On the practical implementation of the project, it can be observed that, on riding in electric mode we will achieve the maximum speed of 30km/h, with the range of 40km in single charge, without producing any amount of CO₂gas in the atmosphere.

Solar charging takes about 4 hours to completely charge the battery of 48 V- 20 AH, using the solar panel of 48 V that produces 1000W (max) under 45700 lux intensity of light.

Safety of the rider is achieved with the help of an electric shocking mechanism, which produces an electric, which can scare the person but will not harm anyone, whereas GPS and GPRS play a vital role in security and safety of rider as well as vehicle.

VI. ADVANTAGE

In the following points, the advantages of riding this electric vehicle are mentioned:-

1. Average running cost is reduced.
2. CO₂ emission is reduced dramatically.
3. Rider safety is achieved with shocking mechanism and accident alarm.
4. Vehicle security with GPS and GPRS.
5. Can reduce rear collision accident cases.
6. In case the rider does not wear a helmet, a buzzer buzzes to notify the rider.
7. Accident due to open side stand while riding can be reduced.

VII. CONCLUSION

In the paper, all the basic information about the safe electric mobility for a women rider is included. The features are categorized into two features, namely; safety and performance. The safety features include shock mechanism, spray system, GPS and GPRS, accident alert, collision alert, side-stand shut off and helmet reminder, while the performance features are dual fuel and solar charging.

VIII. FUTURE ASPECTS

In the present vehicles, all the vehicles run on either petrol or diesel. This scooty can run on dual fuel. Since India is targeting to have an all-electric car fleet by 2030, therefore, if some people start the use of dual fuel, then they get used to riding electric vehicle. Also, the main concern regarding the safety of women, the purity air and number of accidents can be reduced with the use of this vehicle. Electric Vehicle is the rising star of the industry, but it needs advancement in various dimensions, like controller use, better circuits for smooth driving experience, new battery material for long range with short charging time, regenerative breaking can be introduced to compensate the friction losses and utilizing the losses into energy.

ACKNOWLEDGEMENT

The authors would like to express deepest sense of gratitude towards Dr. Rohit Garg (Director MIT Moradabad), parents and friends for their patience, inspiration, guidance, constant encouragement, moral support, keen interest, and valuable

suggestions during preparation of this seminar research paper.

REFERENCES

- [1]. CO2 Emissions from Fuel Combustion Highlights - 2017, International Energy Agency (IEA).
- [2]. <https://www.epa.gov/greenvehicles/greenhouse-gas-emissions-typical-passenger-vehicle>
- [3]. https://www.researchgate.net/publication/323497072_Overview_of_Electric_and_Hybrid_Vehicles
- [4]. K. Araújo, D. Mahajan, R. Kerr and M. da Silva, "Global Bio fuels at the Crossroads: An Overview of Technical, Policy, and Investment Complexities in the Sustainability of Bio fuel Development", Agriculture, (7, 32); pp. 1-22, 2017.
- [5]. Global EV outlook 2017, International Energy Agency (IEA).
- [6]. C. D. Anderson and J. Anderson, Electric and hybrid cars: a history, North Carolina: McFarland & Company, 2010.
- [7]. A. Faiz, C. S. Weaver, and M. P. Walsh, Air Pollution from Motor Vehicles: Standards and Technologies for Controlling Emissions, World Bank Publications, Washington DC, Jan. 1996.
- [8]. <http://pib.nic.in/newsite/PrintRelease.aspx?relid=116719>
- [9]. M. Ehsani, Y. Gao, S. E. Gay, and A. Emadi, Modern Electric, Hybrid Electric, and Fuel Cell Vehicles, New York: CRC Press, 2005.
- [10]. <https://chargedevs.com/newswire/two-new-in-wheel-electric-drive-systems-unveiled/>
- [11]. http://batteryuniversity.com/learn/article/electric_vehicle_ev
- [12]. <http://www.ourenergypolicy.org/wp-content/uploads/2015/04/21725.pdf>
- [13]. <https://pib.gov.in/newsite/PrintRelease.aspx?relid=116719>
- [14]. <https://news.sky.com/story/road-rage-survey-shows-almost-one-in-five-road-users-threatened-with-violence-11627616>
- [15]. M. Montazeri-Gh and M. Naghizadeh, „Development of car drive cycle for emission and fuel economy, Iran university of science and technology, Iran.
- [16]. <http://www.cleanenergyministerial.org/Our-Work/CEM-Campaigns/EV30at30>
- [17]. Openshaw Taylor, „Utilization of electric energy, orient longman pvt. Ltd. 2003.
- [18]. Sanghpriya H. Kamble a, Tom V. Mathew b,*, G.K. Sharma, Development of real world driving cycle: case study Pune, India.

- [19]. Yimin Gao and Mehrdad Ehsani, „Hybrid electric vehicle:overview and state of the art, IEEE 2005, June 2023, CROATIA
- [20]. <https://edition.cnn.com/2019/09/10/health/road-rage-survival-tips-wellness/index.html>
- [21]. Chia-Chang Tong, Wu-Shun Jwo, "An assist-mode hybrid electric motorcycle", power sources, Int journal of power sources,(2007), 174, pp.61-68.
- [22]. ShaikAmjad, S.Neelakrishnan, R.Rudramoorthy, "Review of design considerations and technological challenges for successful development and deployment of plug-in hybrid electric vehicles", Int journal of Resources, Conservation and Recycling, (2010), 14, pp. 1104111

Authors Biography



Hiwani Singh is currently pursuing Bachelor in Technology from Moradabad Institute of Technology in the field of Electronics & Communication Engineering. She has successfully completed

many mini projects in the institute and is currently working on his major project. She has participated in various events and represented the college inside and outside of the institute. She has good knowledge on embedded systems.



Kshitij Shinghal has 20 Years of experience in the field of Academic and is actively involved in research & development activities. He obtained his Doctorate degree from Shobhit University Meerut in 2013, Masters degree

(Digital Communication) in 2006 from UPTU, Lucknow. He started his career from MIT, Moradabad. Presently he is working as an Associate Professor, Deptt of E&C Engg., at MIT Moradabad. He has published number of papers in national journals, conferences and seminars. He has guided two Masters, more than sixty students of B. Tech, and guiding three Ph.D. & M. Tech.



Amit Saxena has 16 Years of experience in the field of Academic. He started his career from MIT, Moradabad. Presently he is working as an Assistant Professor, Deptt of E&C Engg., at MIT Moradabad. He obtained his Bachelor's degree in Electronics &

Communication Engineering from I.E.T., Rohilkhand University, Bareilly and Masters degree (VLSI Design) in 2009 from UPTU, Lucknow. He has published number of papers in international & national journals, conferences and seminars.



Shahbaz Khan is currently pursuing Bachelor in Technology from Moradabad Institute of Technology in the field of Electronics & Communication Engineering. He is currently working on his major project and has

successfully completed many mini projects in the institute. He represented the institute at Zonal and State Level conducted by AKTU University and has been an awarded winner. He has good knowledge of embedded system and mechanical system. He has also participated in various events and represented the college inside and outside of the institute.



Mini Katariya is currently pursuing Bachelor in Technology from Moradabad Institute of Technology in the field of Electronics &

Communication Engineering. She is currently working on her major project and has successfully completed

many mini projects in the institute. She has represented the institute at Zonal Level conducted by AKTU university and has been an awarded winner. She has good knowledge of embedded system.

HiwaniSingh, et. al. "Safe Electric Mobility for Women Rider." *International Journal of Advances in Engineering and Management (IJAEM)*, 2(1), 2020, pp. 426-431.



**International Journal of Advances in
Engineering and Management**
ISSN: 2395-5252



IJAEM

Volume: 02

Issue: 01

DOI: 10.35629/5252

www.ijaem.net

Email id: ijaem.paper@gmail.com